

# C&I 215 kWh Series On-Grid Energy Storage System Solution Technical Proposal

Issue 02  
Date 2024-10-09



**Copyright © Huawei Technologies Co., Ltd. 2024. All rights reserved.**

No part of this document may be reproduced or transmitted in any form or by any means without prior written consent of Huawei Technologies Co., Ltd.

## Trademarks and Permissions



HUAWEI and other Huawei trademarks are trademarks of Huawei Technologies Co., Ltd.

All other trademarks and trade names mentioned in this document are the property of their respective holders.

## Notice

The purchased products, services and features are stipulated by the contract made between Huawei and the customer. All or part of the products, services and features described in this document may not be within the purchase scope or the usage scope. Unless otherwise specified in the contract, all statements, information, and recommendations in this document are provided "AS IS" without warranties, guarantees or representations of any kind, either express or implied.

The information in this document is subject to change without notice. Every effort has been made in the preparation of this document to ensure accuracy of the contents, but all statements, information, and recommendations in this document do not constitute a warranty of any kind, express or implied.

## Huawei Technologies Co., Ltd.

Address: Huawei Industrial Base  
Bantian, Longgang  
Shenzhen 518129  
People's Republic of China

Website: <https://www.huawei.com/>

Email: [support@huawei.com](mailto:support@huawei.com)

## Security Statements

### Vulnerability Handling Process

Huawei's regulations on product vulnerability management are subject to the **Vul. Response Process**. For details about this process, visit <https://www.huawei.com/en/psirt/vul-response-process>.

For vulnerability information, enterprise customers can visit the following web page:

<https://securitybulletin.huawei.com/digitalpower/en/security-advisory>

---

# Contents

---

<b>1 About This Document</b>	<b>1</b>
<b>2 Architecture and Features of the C&amp;I ESS Solution</b>	<b>3</b>
2.1 Architecture	3
2.2 Features	4
<b>3 Introduction to Devices in the C&amp;I ESS Solution</b>	<b>10</b>
3.1 Smart String ESS Configuration	10
3.2 Overview of Devices in the C&I ESS Solution	11
3.2.1 Smart String ESS	11
3.2.1.1 System Architecture Design	12
3.2.1.2 Module Functions	13
3.2.1.3 Monitoring System	14
3.2.1.4 Temperature Control System	15
3.2.1.5 Electrical Safety Design	17
3.2.1.6 Thermal Runaway Suppression Device (TRSD)	19
3.2.2 SmartLogger	24
3.2.3 Smart Power Sensor	25
<b>4 C&amp;I ESS Solution Design</b>	<b>27</b>
4.1 On-Grid Scenarios	27
4.1.1 Low-Voltage Grid Connection Through AC Coupling in ESS-Only Scenarios	27
4.1.2 Low-Voltage Grid Connection Through AC Coupling in PV+ESS Scenarios	28
4.2 Communication Networking	29
4.2.1 Communication Networking of a Single ESS	29
4.2.2 FE Communication Networking of 2–20 ESSs	29
4.2.3 FE Communication Networking of More Than 20 ESSs	30
4.2.4 Optical Fiber Communication Networking	30
4.3 ESS Array Design	31
4.3.1 Solution Design Key Points	31
4.3.2 Typical Array Design	34
4.3.3 Typical Layout of a C&I ESS Array	35
4.3.3.1 Typical Array Layout	35
4.3.4 Charge Solution	37
4.4 ESS Safety Requirements	41

---

<b>5 SmartPVMS (Plant)</b> .....	<b>43</b>
5.1 Introduction .....	43
5.2 Features.....	45
<b>6 Appendix A: Technical Specifications</b> .....	<b>46</b>
<b>7 Appendix B: Model Mapping for the PV+ESS Solution</b> .....	<b>47</b>





# 1 About This Document

## Purpose

This document describes the commercial and industrial (C&I) on-grid energy storage system (ESS) solution in terms of its composition, main devices, communications networking in various scenarios, and device list.

## Symbol Conventions

The symbols that may be found in this document are defined as follows.

Symbol	Description
 <b>DANGER</b>	Indicates a hazard with a high level of risk which, if not avoided, will result in death or serious injury.
 <b>WARNING</b>	Indicates a hazard with a medium level of risk which, if not avoided, could result in death or serious injury.
 <b>CAUTION</b>	Indicates a hazard with a low level of risk which, if not avoided, could result in minor or moderate injury.
 <b>NOTICE</b>	Indicates a potentially hazardous situation which, if not avoided, could result in equipment damage, data loss, performance deterioration, or unanticipated results. NOTICE is used to address practices not related to personal injury.
 <b>NOTE</b>	Supplements the important information in the main text. NOTE is used to address information not related to personal injury, equipment damage, and environment deterioration.

## Change History

Issue	Date	Description
01	2024-07-18	This issue is the initial document for the on-grid solution.

Issue	Date	Description
02	2024-10-09	Updated the communication networking diagram for 50 parallel devices, and added surge protection and leakage current requirements for PDCs.



- Smart Power Sensor (power meter at the grid connection point)
- FusionSolar Smart PV Management System (SmartPVMS)

## 2.2 Features

Highlight	Key Performance	Feature Description	Advantages (Compared with Conventional Solutions)
<b>C2C Dual-link Safety</b>	<b>C2C Electrical-link Safety</b>	<p><b>C2C Electrical-link Safety: Short circuit prevention and isolation</b></p> <ol style="list-style-type: none"> <li><b>Dual cell monitoring</b> The high-precision and automotive-grade battery monitoring integrated circuit (BMIC) collects massive data of cells. The big data self-learning function on the cloud detects 13+ types of faults to provide early warning.</li> <li><b>Six-side pack insulation</b> Patented reinforced insulation materials are used to provide six-side all-round protection for battery packs and cells to survive 30 days of corrosion by electrolyte and 1500 V voltage, preventing enclosure breakdown by arc and cell short circuits.</li> <li><b>Five-level system protection</b> Five-level full-range overcurrent protection (pack-level fuse + rack-level enhanced fuse + rack-level enhanced contactor + PCS-level IGBT disconnection + PCS-level instantaneous circuit breaker), covering the AC/DC protection blind spot between 1200 A and 1600 A in conventional systems. Unique millisecond-level cell-to-ground short-circuit protection, rapid shutdown within 5 ms through the instantaneous circuit breaker</li> <li><b>24-hour consumption assurance</b> RCD leakage detection for AC, DC, and auxiliary power + N/PE grounding disconnection detection, round-the-clock real-</li> </ol>	<p>Conventional solution:</p> <ol style="list-style-type: none"> <li>A battery pack is insulated only on both sides, and insulation is unavailable between cells. The insulation layer can survive only seven days of electrolyte corrosion and 110 V voltage, which may cause shell arcing and cell short circuits.</li> <li>Only three-level or four-level protection is provided, and common fuses and contactors have a protection blind spot between 1200 A and 1600 A. If a high-current cell is short-circuited to the ground, fire may occur in dozens of milliseconds. The fuse reaction time is seconds, the contactor reaction time is hundreds of milliseconds, and the contactor capacity is less than 1200 A. Therefore, effective protection cannot be achieved.</li> <li>Only leakage and short-circuit between the positive and negative buses can be detected. Leakage and short-circuit to the ground and leakage risks on the auxiliary power side cannot be effectively detected, which may cause safety risks such</li> </ol>

Highlight	Key Performance	Feature Description	Advantages (Compared with Conventional Solutions)
		<p>time online insulation monitoring; rapid shutdown of PCS in case of external leakage or short circuit to prevent personnel injury or damage to ESS components due to high current impact</p>	<p>as personal injury.</p>
	<p><b>C2C Heat-link Safety</b></p>	<p><b>C2C Heat-link Safety: Fire mitigation and suppression</b></p> <p><b>1. Cell-level thermal suppression</b> The inter-cell heat insulation layer prevents thermal diffusion of adjacent cells. The liquid cooling plate at the bottom quickly cools battery cells.</p> <p><b>2. Pack-level gas exhaust</b> Unique pack-level directional exhaust design: The IP65 heat-resistant enclosure prevents oxygen from entering the battery packs, eliminating fire risks. The combustible gases are exhausted through an L-shaped duct to prevent combustion and explosion inside the cabinet.</p> <p><b>3. System-level fire extinguishing</b> The battery cabin and power cabin are separated to prevent fires from spreading. The cabin-level independent fire suppression design with pack-level fixed-point perfluorohexanone fire suppression (optional) and cabinet-level aerosol fire suppression enables precise, active, and quick fire suppression.</p> <p><b>4. Consumption-level top explosion vent</b> The high-strength integrated cabinet with hour-level fire resistance prevents fire from spreading outside the cabinet and affecting surrounding assets. The top-mounted explosion vent design prevents explosions and protects people nearby.</p>	<p>Conventional solution:</p> <p>1. No pack-level directional exhaust is available. If cell thermal runaway occurs in a pack, combustible gases will be continuously generated and will cause combustion if the gases come in contact with oxygen at a high temperature. Combustible gases are discharged in the cabinet and will cause combustion if the gas concentration inside the cabinet reaches the explosion limit.</p> <p>2. No explosion vent design is available or an explosion vent is designed at the rear. The cabinet may explode or the pressure is relieved from one side, causing injuries to people around the cabinet.</p>
<p><b>Lower</b></p>	<p><b>More Energy</b></p>	<p><b>1. Actuarial powering</b></p>	<p>Conventional solution:</p>

Highlight	Key Performance	Feature Description	Advantages (Compared with Conventional Solutions)
LCOS		<p>(1) High system efficiency: The new-generation SiC IGBT module, efficient bidirectional balancing topology of packs, three-phase five-bridge topology of PCS, and efficient regulation and hybrid cooling control algorithm are used to achieve the maximum system round trip efficiency (RTE) of 91.3% (@0.25C, 25°C, including auxiliary power supply).</p> <p>(2) Pack-level optimization 2.0: Each battery pack has a built-in energy optimizer 2.0 with an efficient bidirectional balancing topology to achieve real-time active balancing without charge and discharge restrictions. This overcomes the short-board effect and increases the usable energy by 2% in the lifecycle.</p> <p>(3) Phase-level control: Unique asymmetric-phase design of PCS allows for independent power supply of each phase at the maximum capacity, 100% unbalanced three-phase output without a transformer, and grid connection at 0 phase power and 100% unbalanced loads, improving the actual discharge energy of the ESS and reducing electricity costs.</p> <p><b>2. Hybrid cooling</b></p> <p>(1) Low energy consumption: The Huawei-developed thermal management system "Thermal Router" achieves intelligent multi-mode switching, reducing energy consumption by 30%.</p> <p>(2) Long performance life: Triple cooling techniques for system service life <math>\geq 15</math> years</p>	<ol style="list-style-type: none"> <li>1. The maximum RTE is less than 90%.</li> <li>2. No battery pack optimizers are used. After long-term operation, the SOH difference between packs will lead to the short-board effect, and the actual usable energy within the lifecycle will decrease.</li> <li>3. A conventional PCS does not support phase-level control for 100% three-phase unbalanced output without a transformer. In the case of unbalanced loads, the discharge energy will decrease, increasing the electricity cost.</li> <li>4. Conventional air cooling features low efficiency and high energy consumption. In a conventional system that adopts only liquid cooling, the liquid cooling unit runs continuously or frequently starts and stops, resulting in high energy consumption and fault rate. The waste heat of PCS cannot be recycled.</li> <li>5. Thermal management is rough. The battery temperature control effect is poor, battery attenuation is fast, and the service life is only 10 to 12 years (two and discharge cycles per day).</li> <li>6. There is no thermal insulation foam at the port of the liquid cooling pipe or at the bottom of</li> </ol>

Highlight	Key Performance	Feature Description	Advantages (Compared with Conventional Solutions)
		(3) High reliability: Automotive-grade liquid cooling system, full-range anti-condensation, failure rate reduced by 60%	the pack, which is prone to condensation and causes component failures.
	<b>Lower CAPEX</b>	<ol style="list-style-type: none"> <li>1. Three-sided cabinet layout (with a back-to-back spacing of only 0.3 m), saving space and improving energy density per unit area by 8%</li> <li>2. Transported with prefabricated components in a 20-foot container, reducing the transportation cost by 20%.</li> <li>3. No trenching or external auxiliary power cable, reducing installation costs</li> </ol>	<p>Conventional solution:</p> <ol style="list-style-type: none"> <li>1. Due to front-to-rear airflow, maintenance on multiple sides, or explosion vent designed at the rear, and the back-to-back spacing of over 0.6 m, cabinets cannot be combined on three sides.</li> <li>2. If the cabinet height is greater than the standard container height (2.385 m), a higher container is required for transportation, which increases the transportation cost.</li> <li>3. The AC port is close to the ground. A cable trench or raised foundation is required, which increases the installation cost.</li> </ol>
	<b>Lower OPEX</b>	<ol style="list-style-type: none"> <li>1. Pack-level automatic SOC calibration, free of site visits</li> <li>2. No need to change the coolant for 10 years, reducing labor costs and leakage risks</li> </ol>	<ol style="list-style-type: none"> <li>1. Professional engineers need to manually calibrate the SOC onsite. Repeated installation and removal are required for connecting to an external charger, resulting in safety risks.</li> <li>2. A conventional coolant has a service life of only three to five years and thus needs to be changed frequently, which increases the coolant change cost and may cause leakage risks.</li> </ol>

Highlight	Key Performance	Feature Description	Advantages (Compared with Conventional Solutions)
<p><b>One for All</b></p>	<p><b>One Management Platform for the Entire Lifecycle</b></p>	<ol style="list-style-type: none"> <li>1. Smart design SmartDesign 2.0 can recommend an optimal PV &amp; ESS design scheme in a minute by using an intelligent design algorithm. The hour-level PV power generation prediction and PV &amp; ESS collaboration policy allow for accurate ROI calculation.</li> <li>2. Smart scheduling SmartEMO 2.0 can accurately predict PV power production and consumption (accuracy <math>\geq 90\%</math>). The AI-based optimization algorithm achieves multi-mode intelligent scheduling, improving the revenue by 10% or more.</li> <li>3. Smart O&amp;M Four-level comprehensive monitoring from the cell level to system level helps clearly locate faults. Online health diagnosis, analysis of voltage, temperature, internal resistance, SOH, and consistency data, early warning on 13 types of faults, locating of abnormal cells in seconds, and O&amp;M suggestions improve O&amp;M efficiency.</li> </ol>	<p>Conventional solution:</p> <ol style="list-style-type: none"> <li>1. No design tool is available. Manual design is time-consuming and costly.</li> <li>2. Operational policies are manually set based on experience, which cannot ensure optimal benefits.</li> <li>3. Manual onsite health diagnosis results in high costs and low O&amp;M efficiency.</li> </ol>
	<p><b>One Solution for All Scenarios</b></p>	<ol style="list-style-type: none"> <li>1. Charge/Discharge at constant power Batteries can be charged and discharged at a constant power at 0.5C regardless of the SOC to support frequency regulation and VPP scenarios.</li> <li>2. Intelligent harmonic suppression THDi <math>\leq 1.5\%</math> at rated power, applicable to scenarios in which high power quality is required, such as precision manufacturing</li> <li>3. Intelligent circulating current suppression: With the parallel circulating current balancing algorithm, a maximum of 50 devices can be connected in parallel in an ESS array or a</li> </ol>	<p>Conventional solution:</p> <ol style="list-style-type: none"> <li>1. The THDi is up to 3%, compromising the power quality.</li> <li>2. Parallel circulating current exists. A maximum of 10 devices can be connected in parallel.</li> <li>3. The EMC performance is Class A (industrial environment), compromising the stable operation of electrical equipment and causing a risk of radiation on personnel.</li> </ol>

Highlight	Key Performance	Feature Description	Advantages (Compared with Conventional Solutions)
		<p>maximum of 20 devices can be connected in parallel in a PV+ESS array to support large- and medium-sized C&amp;I scenarios, such as iron and steel industry and chemical industry.</p> <p>4. Intelligent electromagnetic interference suppression: Meets class B EMC requirements, the highest EMC class in the industry, applicable for deployment in densely populated scenarios such as shopping malls, supermarkets, and hotels.</p>	

# 3 Introduction to Devices in the C&I ESS Solution

## 3.1 Smart String ESS Configuration

Model	LUNA2000-215-2S10	LUNA2000-215-2S12
Overview	0.5CP, without DCDC, 380/400/415 V AC output, standard edition	0.5CP, without DCDC, 380/400 V AC output, advanced safety edition
Nominal energy (kWh)	215.0	215.0
Rated charge/discharge rate (CP)	0.5	0.5
Battery pack model	LUNA2000-54-2E1	LUNA2000-54-2E1
Rated battery capacity (Ah)	280.0	280.0
Battery configuration	(1P60S)4S	(1P60S)4S
Rated power grid voltage (V)	380/400/415	380/400
DCDC converter configuration	0	0
PCS configuration	1	1
PCS rated power (kW)	108	108
Rack Control Module (RCM) disconnect	0	1
Pack-level optimization 2.0	Yes	Yes
Pack-level directional exhaust	Yes	Yes
Pack-level gas fire suppression	No	Yes
Cabinet-level aerosol fire suppression	Yes	Yes

<b>Cabinet-level active exhaust system</b>	No	Yes
<b>Explosion vent</b>	Top	Top
<b>EMC requirement</b>	Class B	Class B
<b>Certification standards*</b>	GB/T 36276-2018, IEC 62619, IEC 62477-1, etc.	GB/T 36276-2018, IEC 62619, IEC 62477-1, etc.
<b>Marketable regions*</b>	Outside China (excluding Japan, South Korea, A-Type countries)	Chinese mainland

\* For details about the certification standards, see the certification list. The actual marketable regions are subject to the saleable product list.

## 3.2 Overview of Devices in the C&I ESS Solution

### 3.2.1 Smart String ESS

The LUNA2000-215-2S10 and LUNA2000-215-2S12 Smart String ESSs (ESS for short) can be charged from or discharged to an external grid through the rectification of a Smart PCS to support the maximum self-consumption of PV power, time-of-use (TOU) arbitrage, and reduction of the capacity charge.

The ESS is a prefabricated all-in-one energy storage system that integrates the prefabricated modular structure system, power supply and distribution system, monitoring system, environment control system, fire suppression system, and integrated cabling system. It features high safety and reliability, fast deployment, low cost, high efficiency, and intelligent management.

**Figure 3-1** LUNA2000-215-2S10 and LUNA2000-215-2S12



### 3.2.1.1 System Architecture Design

The C&I Smart String ESS supports rack-level management, pack-level optimization 2.0 (pack-level intelligent active balancing), Hybrid cooling management, directional exhaust vent, top-mounted explosion vent, and optional pack-level fire suppression. The ESS supports three-sided cabinet layout. The battery packs and power modules are installed in different cabins. The Liquid Thermal Management System (LTMS) is mounted on the door. The ESS has an all-in-one architecture. Only AC output power cables and communications cables need to be installed onsite.

The following figures show the physical layout of modules such as the battery packs, main power PCS, RCM, power distribution unit, LTMS, sensor, and fire suppression system.

**Figure 3-2** ESS AC coupling 0.5P: 4-pack physical architecture

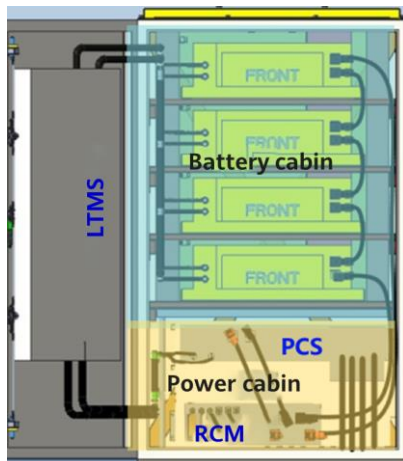

**Figure 3-3** ESS interior

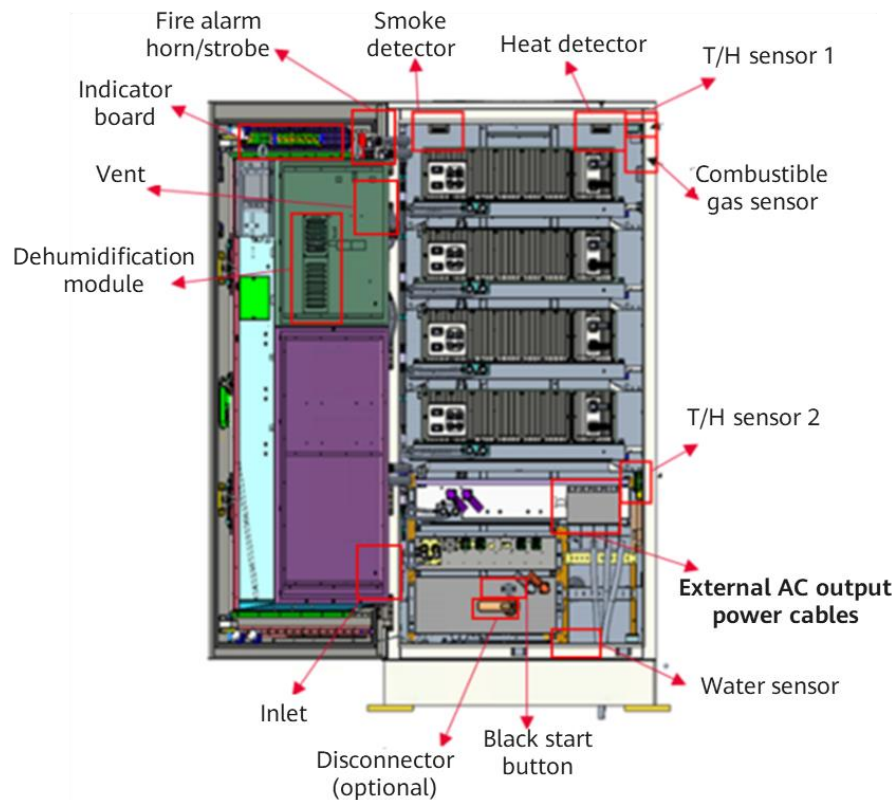

### 3.2.1.2 Module Functions

1. RCM: consists of the battery control unit (BCU), rack power control board (RPCB), contactor, fuse, power copper bar, and heat dissipation fan. The RPCB contains the low-voltage auxiliary power supply for the ESS and provides two 12 V DC power supplies, one for the LTMS and the other for low-voltage electrical devices. The BCU is the main control unit of the ESS. It communicates with external devices in the northbound direction and controls and manages internal devices in the southbound direction. The RCM also provides an independent 220 V AC power supply for air conditioners, which is controlled by a circuit breaker.
2. Main power PCS: converts 648–864 V DC voltage into 380–415 V AC voltage, supports 3-phase 4-wire and 100% unbalanced loads, uses CAN FD for communication, and supports hardware rapid shutdown.
3. Battery pack: composed of cells connected in series and parallel (1P60S in this solution). It is the minimum energy storage unit that stores or provides energy. Data such as the battery voltage, battery current, and battery temperature is reported.
4. LTMS: includes a highly integrated thermal management module developed by Huawei. It ensures the optimal operating temperature for each module of the ESS and optimal temperature and humidity inside the cabinet through adaptive adjustment and control.
5. General power distribution: 1000 V DC high-voltage DC design for fault isolation or power-off maintenance

### 3.2.1.3 Monitoring System

The internal monitoring unit of the ESS consists of the BCU and battery monitoring unit (BMU). The external monitoring unit of the ESS is the SmartLogger. In the single-cabinet scenario, the SmartLogger can be placed inside or outside the ESS.

Level	Function
Level 1: BMU	<ol style="list-style-type: none"> <li>1. Monitors cell voltage and temperature, and aggregates and reports the collected data.</li> <li>2. Checks the sampling circuit in real time, ensuring sampling reliability.</li> <li>3. Activates the active balancing module in the pack.</li> </ol>
Level 2: BCU	<ol style="list-style-type: none"> <li>1. Receives the cell voltage and temperature reported by the BMU through daisy chain communication.</li> <li>2. Controls the active balancing module in the pack through CAN communication and balances capabilities between packs.</li> <li>3. Receives the total rack voltage and current reported by the RPCB and calculates the SOC.</li> <li>4. Calculates the battery rack SOH.</li> <li>5. Manages the normal running and alarm information of batteries in the rack, controls the charge and discharge currents of the battery rack based on control requirements, and delivers balancing commands based on the battery status in the rack.</li> <li>6. Connects to the environment management system and fire suppression system in the southbound direction to monitor the operating environment and fire protection status of the ESS.</li> <li>7. Obtains the alarms and protection status of the ESS to ensure the safe operation of the system.</li> </ol>

**Figure 3-4** Monitoring unit networking diagram

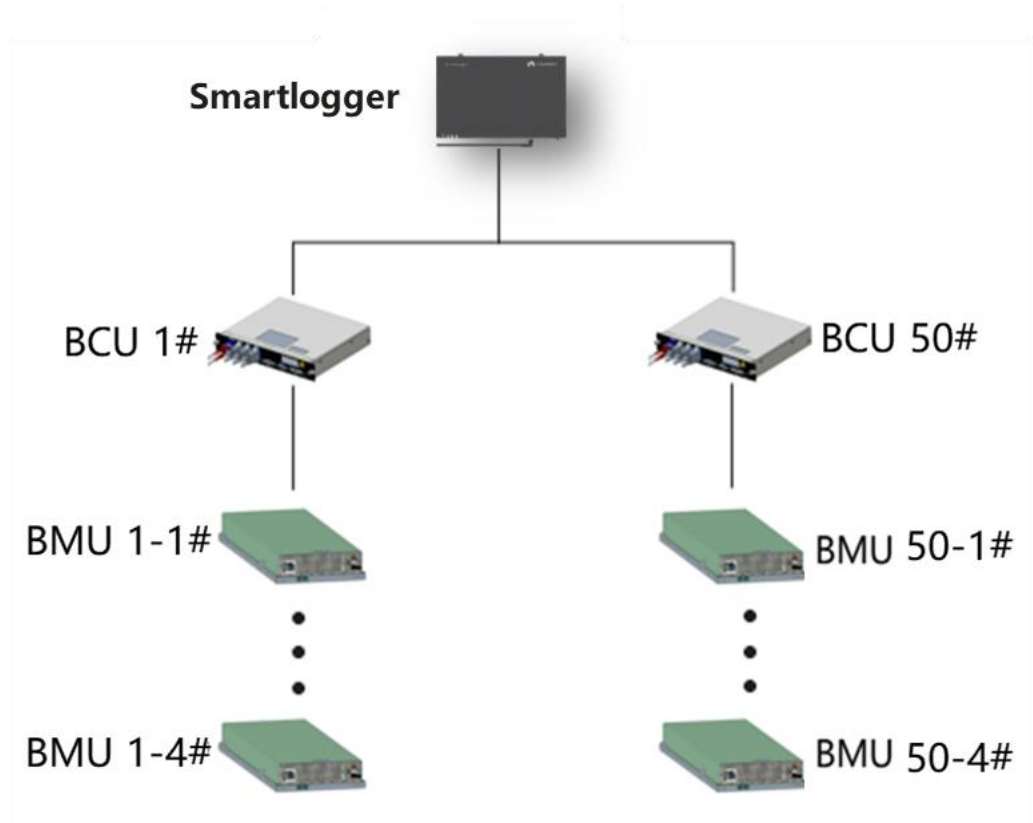

### 3.2.1.4 Temperature Control System

The C&I ESS consists of a battery cabin and a power cabin. The LTMS is embedded in the ESS to improve space utilization. The LTMS provides cold or hot coolant (with a 50% volume concentration of ethylene glycol solution). The circulating pump in the LTMS transmits the cold or hot coolant to the battery cabin. The coolant exchanges heat with the cold plate at the bottom of the battery pack to keep the pack temperature within a constant range.

**Figure 3-5** Embedded LTMS

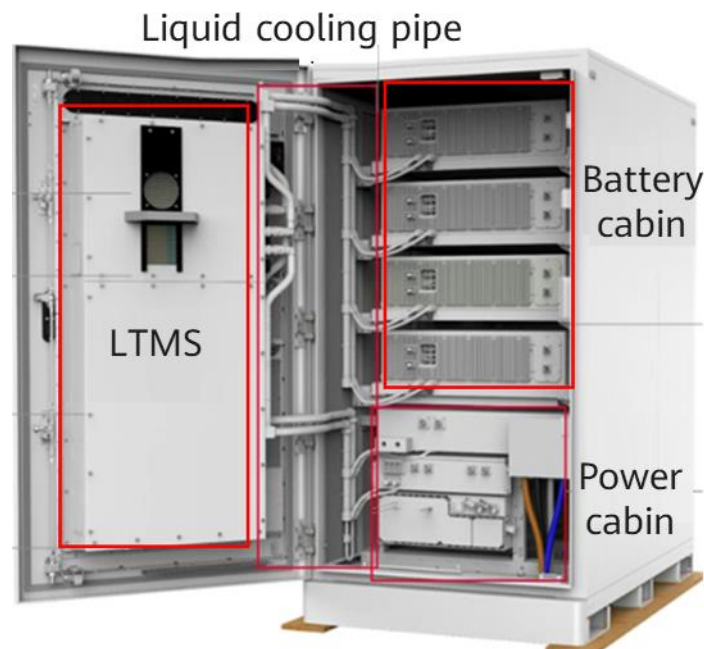

The Huawei-developed LTMS consists of the compressor, fan, heating pump, heat exchanger, and multi-way valve. It automatically adjusts the eight-way valve and control module to meet different cooling requirements, allowing the ESS to operate properly in different outdoor environments. The LTMS includes a highly integrated thermal management module developed by Huawei. It ensures the optimal operating temperature for each module of the ESS and optimal temperature and humidity inside the cabinet through adaptive adjustment and control. The LTMS can intelligently select a cooling or heating mode. There are six modes:

- **Active liquid cooling:** When the ambient temperature outside the cabinet is high, the system switches to the active liquid cooling mode and provides cold coolant (with a 50% volume concentration of ethylene glycol solution) through the compressor. The pump transmits the low-temperature cold coolant to the battery pack cold plate to cool the battery pack, and transmits the cold coolant with a relatively high temperature to the PCS cold plate to cool the PCS.
- **Natural air cooling:** When the ambient temperature outside the cabinet is relatively low, the coolant exchanges heat with the external air through the heat sink to provide cold coolant for the heat generation modules (battery packs and PCSs). Under the same conditions, natural air cooling reduces the auxiliary power consumption of the ESS by about 50% compared with compressor cooling. When the ambient temperature is relatively low, the system preferentially switches to the natural air cooling mode. This reduces the auxiliary power consumption and improves the cycle efficiency and 24-hour comprehensive energy efficiency of the ESS.
- **Electric heating:** When the ambient temperature outside the cabinet is lower than  $-5^{\circ}\text{C}$  and the battery temperature needs to be raised, the system automatically selects the electric heating mode and enables the PTC electric heater to provide hot coolant with the required temperature for the battery pack. When the battery temperature reaches the heating stop threshold, the PTC electric heater stops running.

- **Heating through heat pump:** When the ambient temperature outside the cabinet is higher than  $-5^{\circ}\text{C}$  and the battery temperature needs to be raised, the system automatically enables the heat pump to provide hot coolant with the required temperature for the battery pack. When the battery temperature reaches the heating stop threshold, the heat pump stops running. Compared with the electric heater, the heat pump mode consumes less auxiliary power.
- **Waste heat Utilization:** When the ambient temperature outside the cabinet is low, the battery pack needs to be heated, and the PCS generates heat during operation, the system automatically switches to this mode. By switching the mode inside the coolant pipe system, the system transfers the heat in the PCS to the battery pack with coolant as the carrier, making full use of the waste heat in the power cabin.
- **Intra-cabinet intelligent dehumidification and cooling:** When the air humidity inside the cabinet is high, the system automatically starts the intelligent dehumidification module in the LTMS to dehumidify the air till the specified dehumidification stop threshold. When the temperature inside the cabinet is high, the system starts the compressor and fan of the LTMS to supply low-temperature dry air to the cabinet. This scheme can effectively reduce the humidity and temperature inside the cabinet to improve system reliability. It does not require an additional dehumidification system, which is mandatory in other vendors' solutions, and makes the software control logic more intelligent. In addition, the liquid-cooled ESS can transmit cold air to control the temperature inside the cabinet.

The bottom cold plate of the pack adopts the multi-homocentric flow path design that implements single-pipe flow and ultra-low flow resistance. The jet impingement cooling inside the pipe produces good cooling effect. The inlet and outlet are located at the same position, offering better temperature uniformity compared with the traditional U-shaped flow path.

**Figure 3-6** Multi-homocentric flow path of the bottom cold plate of the pack

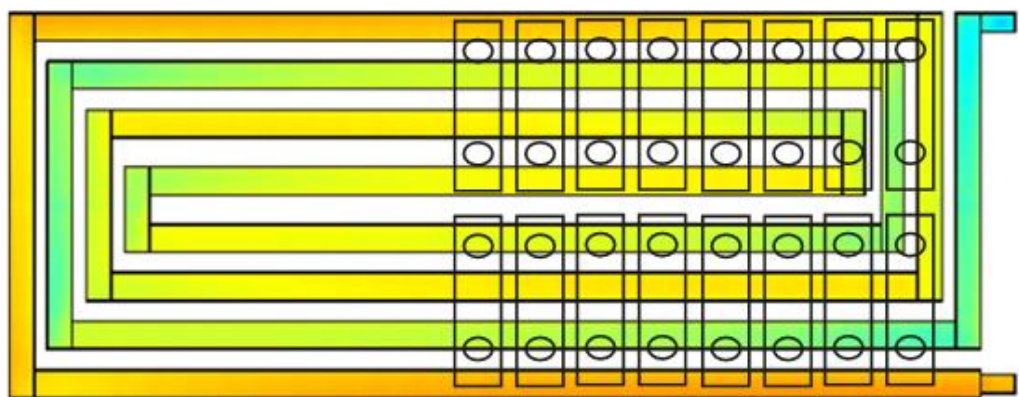

### 3.2.1.5 Electrical Safety Design

#### 1. Pack Insulation & Heat Insulation Design

The system provides six-side all-round protection for cells inside the battery pack. Enhanced insulation materials are used at the bottom and top of a cell. Ceramic composite straps are added on both sides of a cell to prevent enclosure

breakdown by arc and cell short circuits. Heat insulation pads are used between cells to prevent thermal runaway of a cell from spreading to neighboring cells.

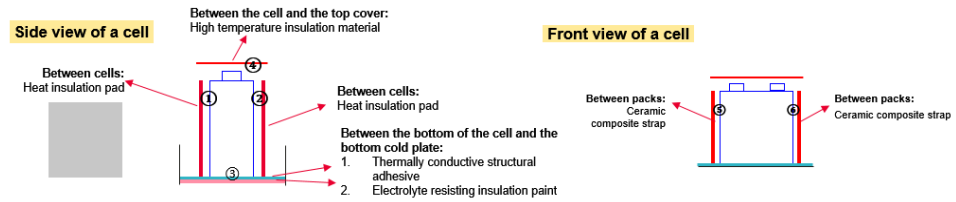

## 2. System Electrical Protection

The system adopts five-level full-range overcurrent protection (pack-level fuse + rack-level enhanced fuse + rack-level enhanced contactor + PCS-level IGBT disconnection + PCS-level instantaneous circuit breaker), covering the AC/DC protection blind spot between 1200 A and 1600 A in conventional systems.

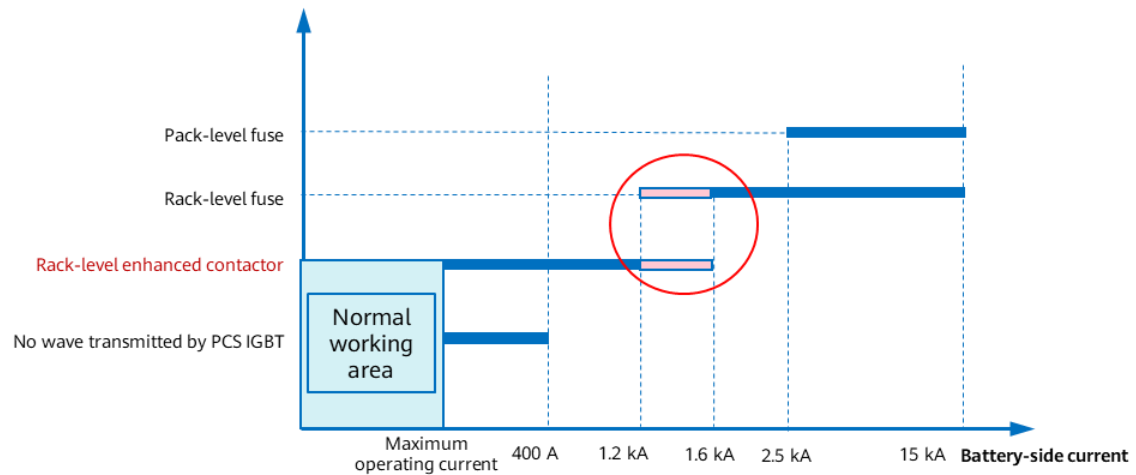
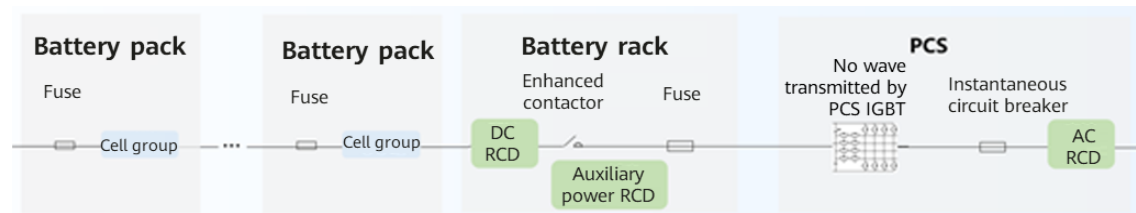

Unique millisecond-level cell-to-ground short-circuit protection allows for rapid shutdown within 5 ms through the instantaneous circuit breaker.

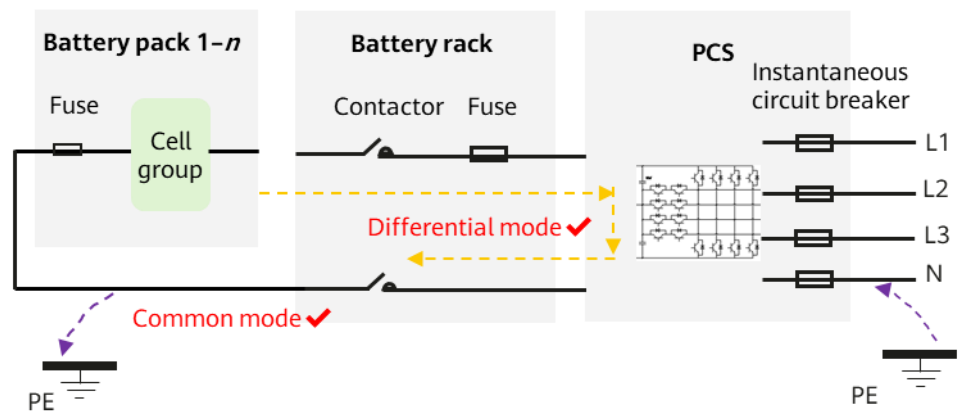

### 3.2.1.6 Thermal Runaway Suppression Device (TRSD)

#### 1. Thermal Runaway Detection

Detection by system sensors:

Smoke and fire can be detected within minutes for the pack, power component, power distribution unit, and LTMS inside the cabinet. After detecting a fire, the cabinet generates an audible and visual alarm. One smoke sensor, one temperature sensor, one CO sensor, and two temperature and humidity sensors are installed inside the cabinet. One fire alarm horn/strobe is installed outside the cabinet.

The following is the diagram.

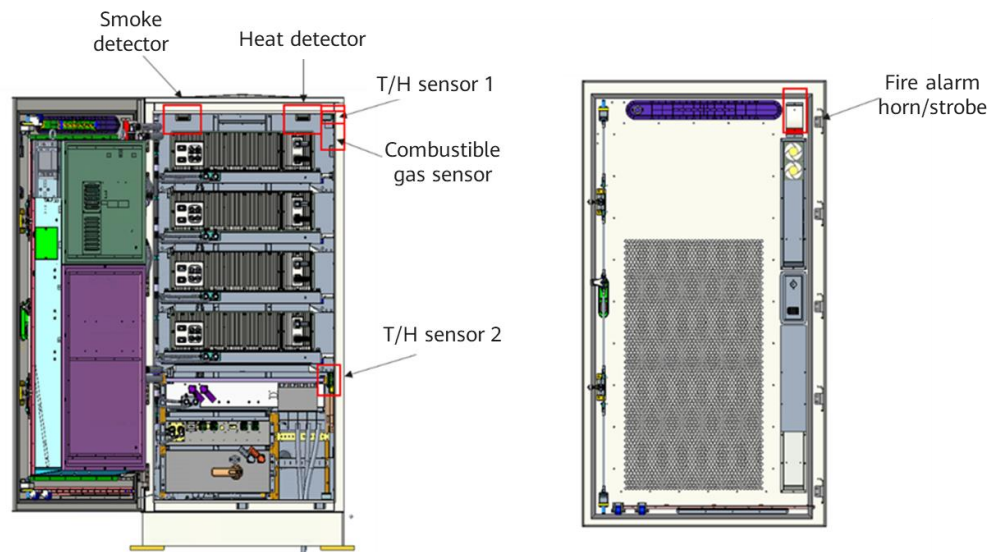

#### 2. Pack-Level Directional Exhaust

When a large amount of gas is generated due to thermal runaway of a pack, the combustible gas is directly discharged to the outside of the system through the explosion-proof valve, ventilation duct, and smoke outlet. This prevents a large amount of combustible gas from accumulating inside the cabinet and causing explosion risks.

The following figure shows the directional exhaust duct design.

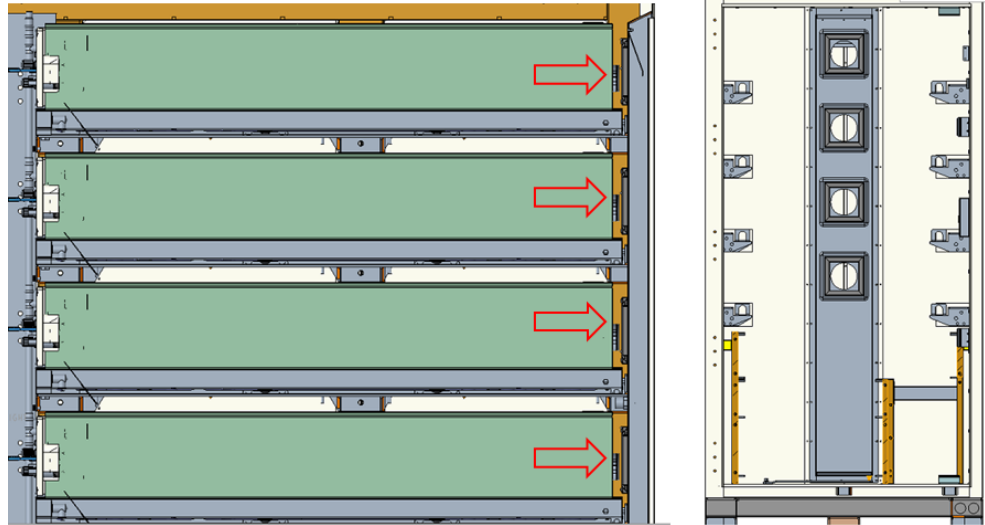

### 3. Aerosol Fire Suppression

In the event of an electrical fire in the power cabin, the aerosol modules sense the temperature rise and release a large number of aerosol particles that cover the entire power cabin to quickly suppress the fire. The triggering mode is passive triggering by temperature sensing, and the triggering temperature is  $185\pm 15^{\circ}\text{C}$ .

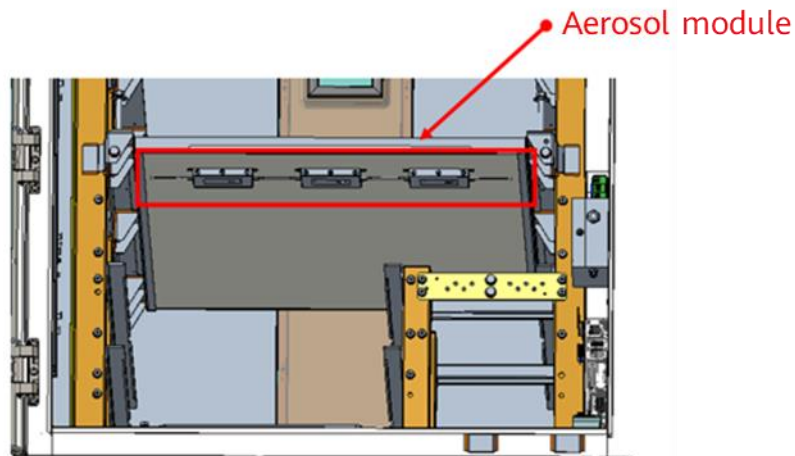

### 4. Pack-Level Fire Suppression (Optional)

Applicable only to the LUNA2000-215-2S12 model (not marketed outside China Mainland).

The TRSD communicates with the ESS. When a thermal runaway alarm is generated for any pack, the ESS sends a fault signal and pack location information to the TRSD. After receiving the information, the TRSD starts to release extinguishant into the pack. The heat in the pack is absorbed quickly by the extinguishant to rapidly cool the pack, suppressing the thermal runaway process.

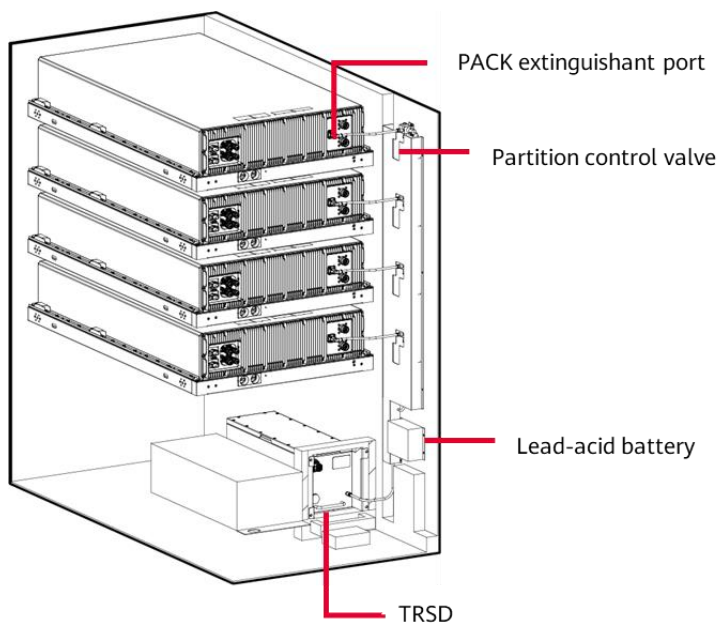

#### 5. Automatic Exhaust (Optional)

Applicable only to the LUNA2000-215-2S12 model (not marketed outside China Mainland).

Gas exhaust starts when the CO sensor detects that the density of combustible gases exceeds the preset threshold, and stops when the density falls below the preset threshold.

The following shows the automatic exhaust logic diagram.

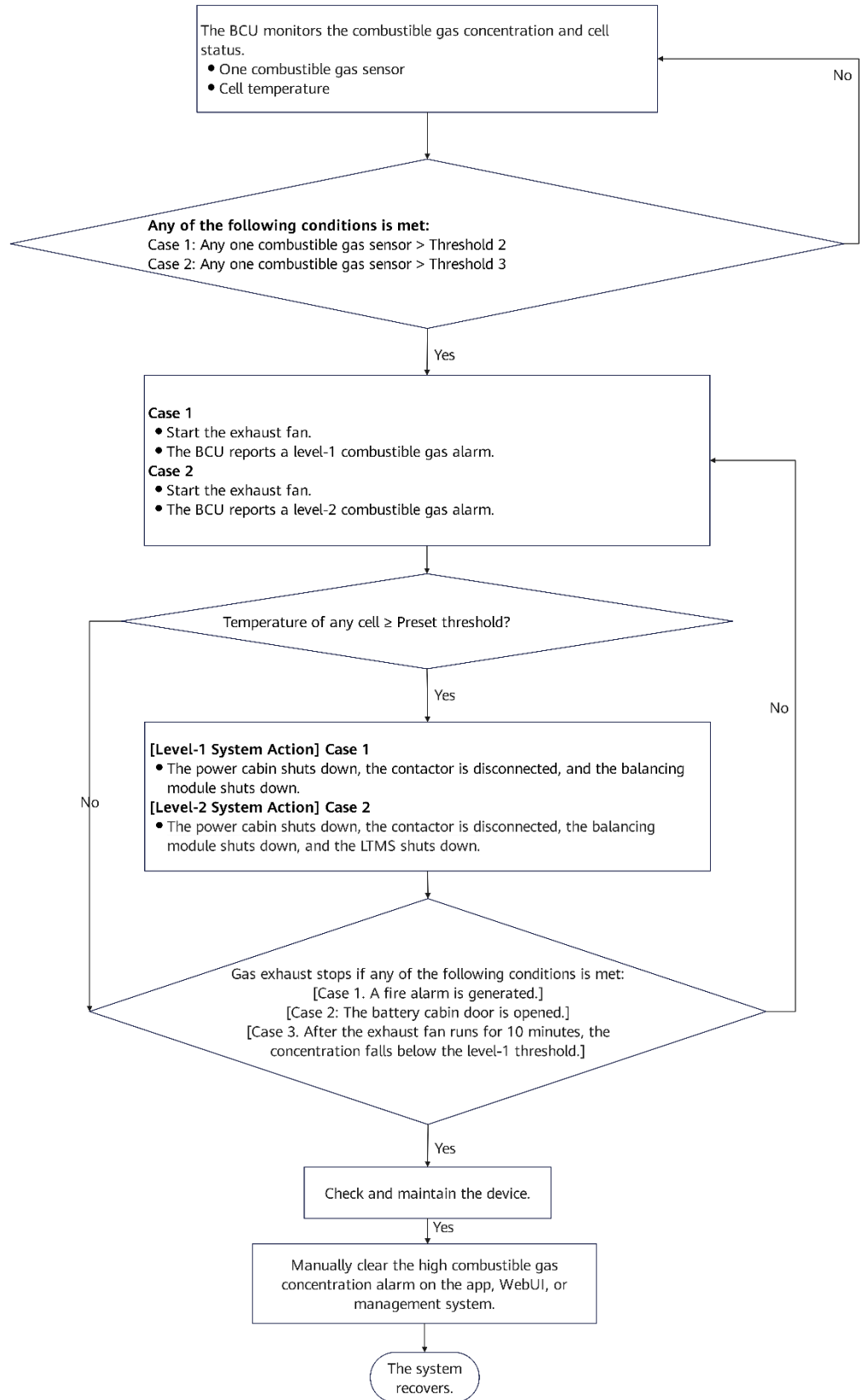

## 6. Top-Mounted Explosion Vent

When the positive pressure oxygen blocking for packs and ventilation duct capability reach the limit or fail, the explosion is discharged from the top of the cabinet. After the explosion relief, the rupture disks on the top are broken. The panel will be open but will not disconnect because it is secured by the stranded cable.

The following figure shows the top-mounted exposition vent design.

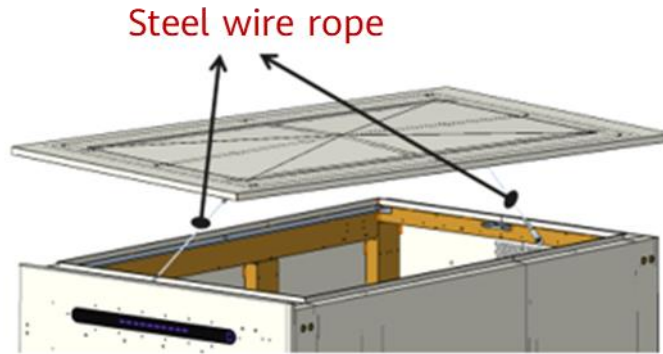

### 7. Thermal Runaway Suppression Control Logic

When thermal runaway occurs in any pack, the ESS is powered off, air exhaust is disabled, and the LTMS is powered off. The BCU opens the partition control valve of the corresponding pack to release extinguishant. The fire alarm horn/strobe is started at the same time.

When a cabinet-level fire occurs, the ESS is powered off, air exhaust is disabled, the LTMS is powered off, and the fire alarm horn/strobe is started.

The following figure shows the thermal runaway control logic.

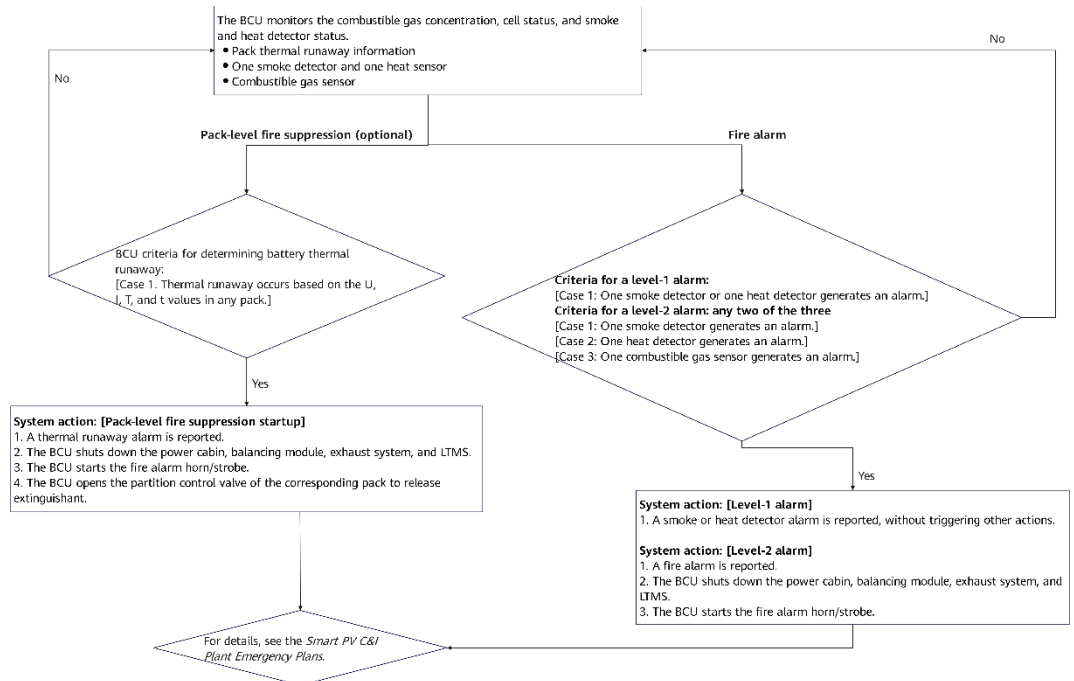

### 3.2.2 SmartLogger

The SmartLogger3000 is recommended for the C&I PV+ESS system networking. The SmartLogger3000A/B/C comes standard with two optical ports, one WAN port, one LAN port, and three RS485 ports. The SmartModule provides four LAN ports and three RS485 ports.

For PV+ESS scenarios outside China, the PV side supports RS485/MBUS networking, and FE ring networking is recommended for the ESS. The ESS also supports fiber ring networking.

The SmartLogger3000 supports FE or optical fiber networking in the northbound direction.

The power meter at the grid connection point is connected to the RS485 port on the SmartLogger3000 through an RS485 communications cable.

The SmartLogger monitors and manages PV+ESS system. It converges ports, converts protocols, collects and stores data, and centrally monitors and maintains the equipment in PV+ESS system. The SmartLogger has the following features:

- Intelligent and flexible: Connects to the inverter, ESS, and optimizer, and supports one-click commissioning.
- Easy to use: Supports wizard-based settings, facilitating parameter settings and device connection.

**Figure 3-7** SmartLogger appearance and technical specifications



Item	Technical Specifications
Power adapter	AC input: 100–240 V, 50 Hz/60 Hz
	DC output: 12 V/2 A
DC power supply	24 V, 0.8 A
Power consumption	SmartLogger3000A (typical): 8 W
	SmartLogger3000B (typical): 9 W
	SmartLogger3000B + SmartModule1000A (typical): 10 W
	Maximum: 15 W
Dimensions (W x H x D)	Including mounting ears: 259 mm x 160 mm x 59 mm
	Excluding mounting ears: 225 mm x 160 mm x 44 mm

Item	Technical Specifications
Net weight	2 kg
Operating temperature	-40°C to +60°C
Storage temperature	-40°C to +70°C
Relative humidity	5%–95% RH
IP rating	IP20
Installation mode	Installed on a wall or guide rail
Maximum operating altitude	4000 m
Pollution degree	2
Corrosion level	B
Ethernet ports (WAN and LAN)	Two 10M/100M/1000M auto-sensing ports
Ethernet optical ports (SFP)	Two ports, supporting 100M/1000M SFP/eSFP optical modules
MBUS ports	One port, supporting a maximum AC input voltage of 800 V
RS485 (COM)	Three ports; supported baud rates: 1200 bps, 2400 bps, 4800 bps, 9600 bps, 19200 bps, 115200 bps
USB	USB2.0
Power output port	One port; DC output: 12 V, 0.1 A
Digital input (DI) port	Four inputs; supports only the access from relay dry contacts
Digital output (DO) port	Two ports; relay dry contact outputs, with NO or NC contacts; 12 V/0.5 A signal voltage
Analog input (AI) port	Four inputs; AI1: supports 0–10 V voltage (passive); AI2–AI4: support 4–20 mA or 0–20 mA input current (passive)
4G antenna port (4G)	One port; SMA-K (external screw inner hole) port, used with an antenna that has the SMA-J (internal screw inner pin) port

### 3.2.3 Smart Power Sensor

For collaborative control of the PV+ESS system, a Smart Power Sensor (power meter at the grid connection point) is required. Currently, the SmartPS-80AI-T0 (DTSU666-HW and YDS60-80) has been verified. For other meter models, submit a verification application to the RAT.

In the 10 kV on-grid scenario, a 10 kV/100 V potential transformer (PT) with a minimum precision of 0.5s is required.

The current on the secondary side of the current transformer (CT) is 1 A or 5 A. The minimum CT sampling precision is 0.5s.

**Figure 3-8** Smart Power Sensor wiring diagram (For details, see the *Commercial and Industrial On-Grid Energy Storage Solution Quick Guide*.)

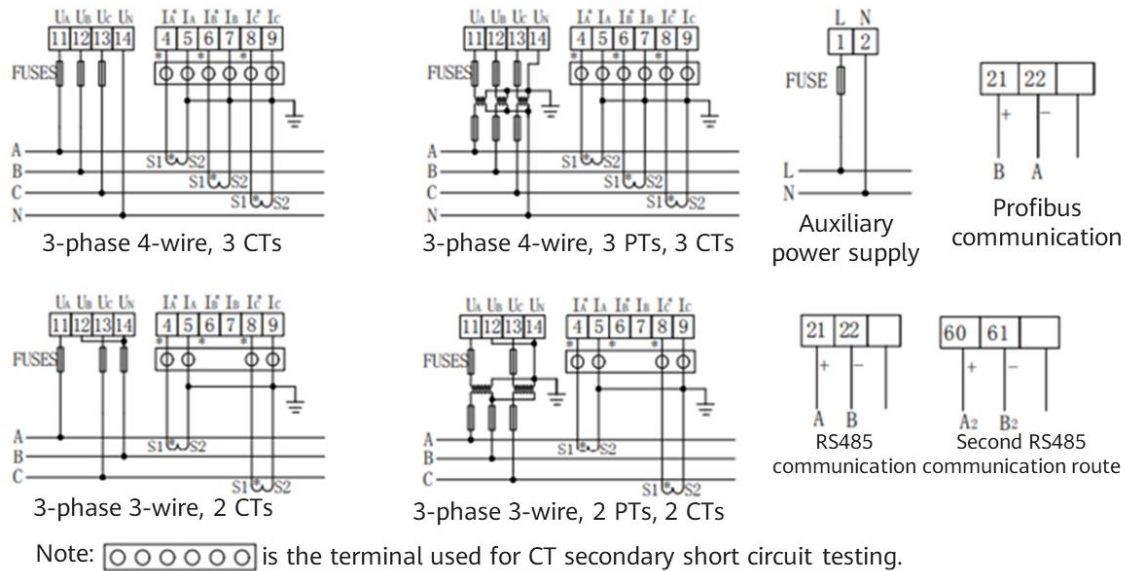

# 4 C&I ESS Solution Design

## 4.1 On-Grid Scenarios

### 4.1.1 Low-Voltage Grid Connection Through AC Coupling in ESS-Only Scenarios

In small- and medium-sized ESS-only scenarios, the ESS is mainly used for TOU arbitrage, charge/discharge based on dispatch, peak shaving, and power boost.

The C&I Smart String ESSs LUNA2000-215-2S10 and LUNA2000-215-2S12 are used.

**Figure 4-1** Low-voltage grid connection through AC coupling in ESS-only scenarios

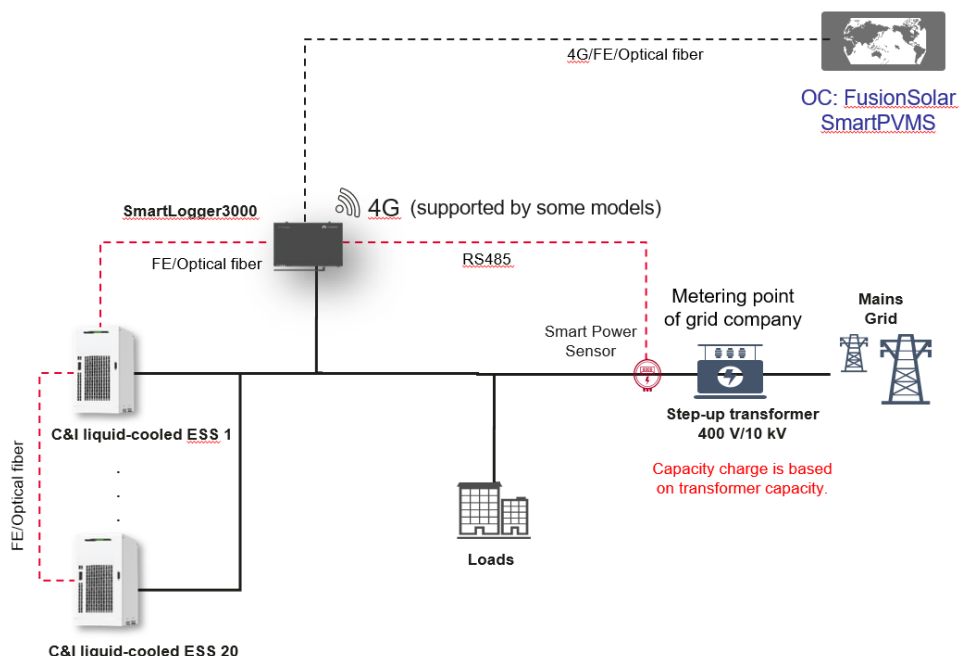

Solution scenario characteristics:

Typical scenario: 0.5C ESS charge/discharge rate; 2-hour power backup

Only one SmartLogger and one grid connection point are supported. A maximum of 50 ESSs can be connected in parallel, a single SmartLogger supports a maximum of 20 C&I ESSs (For details, see the communication networking diagram.)

At the grid connection point, only Huawei C&I meters are supported (SmartPS-80AI-T0). Customers need to purchase CTs (XXX A/5 A or 1 A) with a minimum precision of 0.5s.

### 4.1.2 Low-Voltage Grid Connection Through AC Coupling in PV+ESS Scenarios

In this scenario, the ESS is mainly used for maximum self-consumption of PV power, TOU arbitrage, charge/discharge based on dispatch, peak shaving, and power boost.

PV inverters: M3, V3-C, V5, V5+, and V6. The M3 can work with 1-to-1 and 1-to-2 optimizers, and the V6 can work with 1-to-2 optimizers.

The C&I Smart String ESSs LUNA2000-215-2S10 and LUNA2000-215-2S12 are used.

**Figure 4-2** Low-voltage grid connection through AC coupling in PV+ESS scenarios

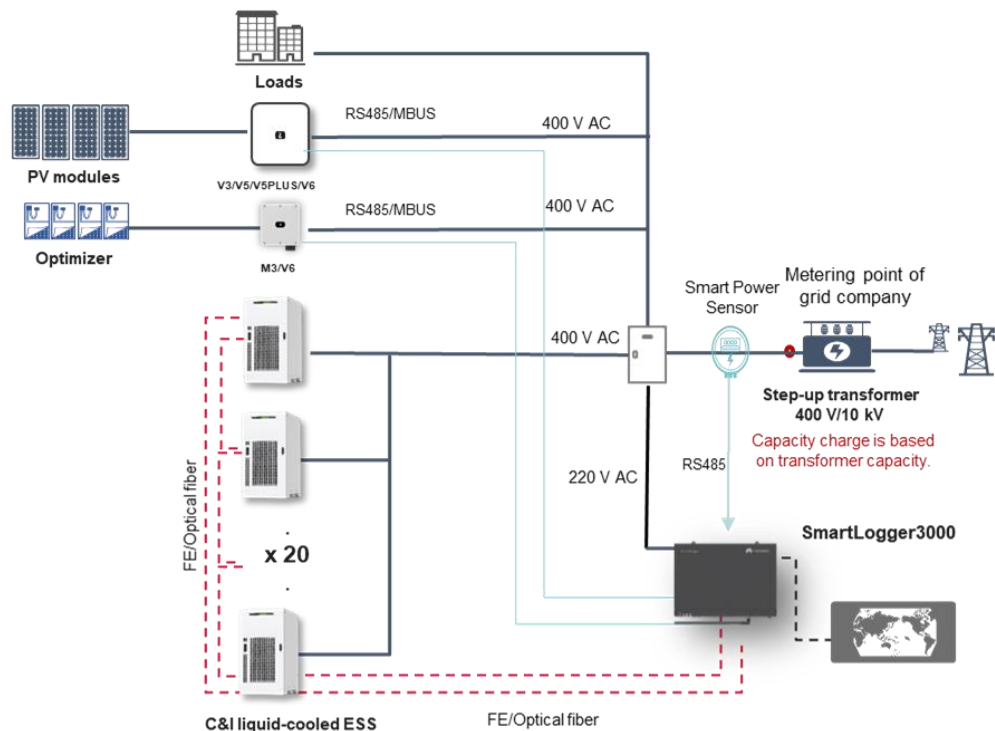

Solution scenario characteristics:

Typical scenario: 0.5C ESS charge/discharge rate; 2-hour power backup

In the PV+ESS on-grid scenario, only one SmartLogger and one grid connection point are supported. A maximum of 20 ESSs and 30 PV inverters (V3-C/M3/V5/V5+/V6 series inverters) are supported.

At the grid connection point, only Huawei C&I meters are supported (SmartPS-80AI-T0). Customers need to purchase CTs (XXX A/5 A or 1 A) with a minimum precision of 0.5s.

MBUS networking: applicable only to medium-voltage on-grid scenarios or non-low-voltage utility grid scenarios (on-grid; industrial environment). For details, see the inverter user manual.

## 4.2 Communication Networking

The SmartLogger3000 is recommended for the C&I PV+ESS system networking. The SmartLogger3000A/B/C comes standard with two optical ports, one WAN port, one LAN port, and three RS485 ports. The SmartModule provides four LAN ports and three RS485 ports.

For PV+ESS scenarios outside China, the PV side supports RS485/MBUS networking, and FE ring networking is recommended for the ESS. The ESS also supports fiber ring networking.

The SmartLogger3000 supports FE or optical fiber networking in the northbound direction.

The power meter at the grid connection point is connected to the RS485 port on the SmartLogger3000 through an RS485 communications cable.

### 4.2.1 Communication Networking of a Single ESS

In the single ESS scenario, the SmartLogger can be installed in the ESS and must be connected to the FusionSolar SmartPVMS.

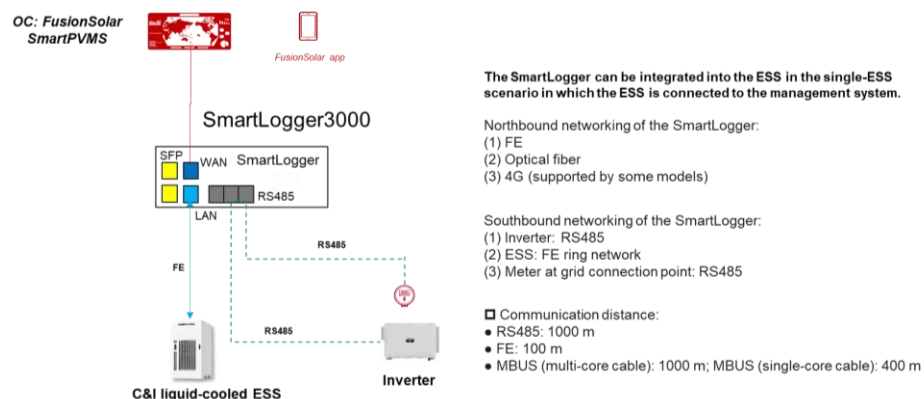

### 4.2.2 FE Communication Networking of 2–20 ESSs

Application scenario: A single array contains 2 to 20 ESSs.

**Figure 4-3** FE ring network topology for the ESSs

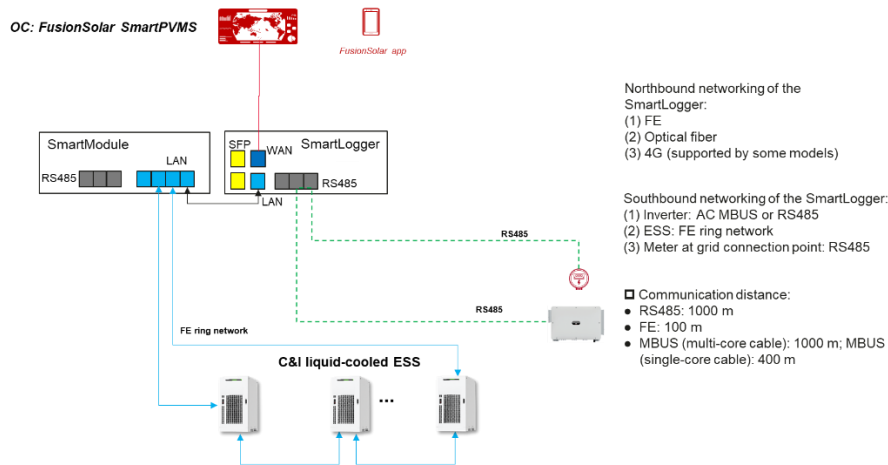

### 4.2.3 FE Communication Networking of More Than 20 ESSs

In this scenario, a third-party EMS must be added to control the optical storage and multiple SmartLoggers. The third-party EMS implements 2S countercurrent prevention, maximum self-consumption, and peak-to-valley arbitrage. Functions such as demand restriction (Peak Shaving); The third-party EMS must be able to access the SmartLogger and communicate with the SmartLogger using the IEC104 and Modbus protocols.

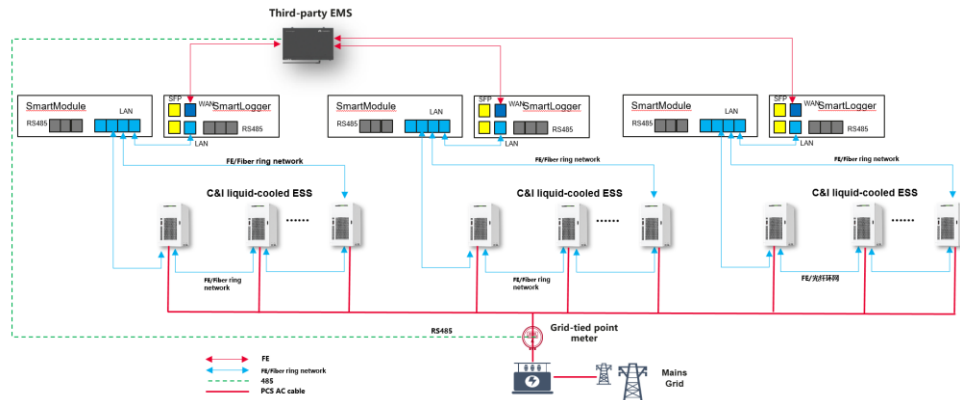

### 4.2.4 Optical Fiber Communication Networking

#### 1. Optical fiber networking for 20 ESSs

The ESS can use the optical fiber communication networking, which supports a maximum of 20 cabinets.

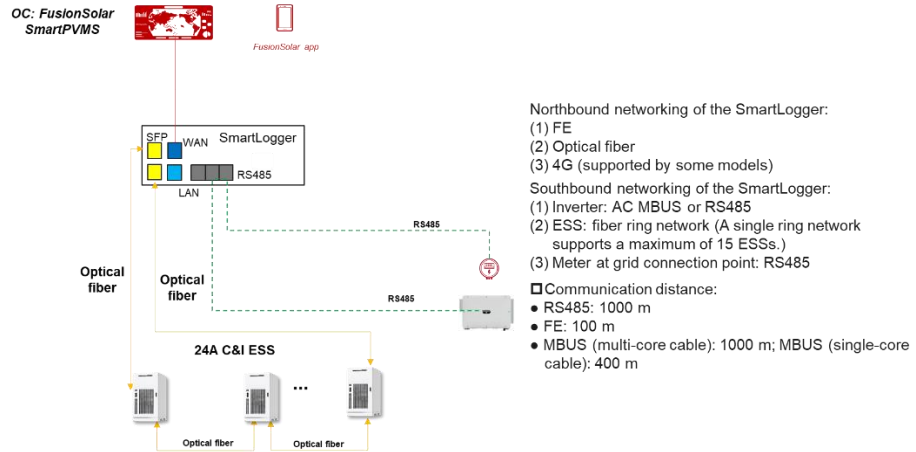

## 4.3 ESS Array Design

### 4.3.1 Solution Design Key Points

Key Design Point	Description
Power distribution cabinet requirements	Each ESS connects to a power distribution switch. The recommended rated current of each power distribution switch is 250 A, <b>The leakage current is greater than 1 A, the power distribution cabinet connected to the ESS must be configured with a surge protector.</b>
External auxiliary power supply requirements	You are advised to use the mains power or a reliable power source as the auxiliary power supply for the ESS. Do not obtain power from the AC side of the PV inverter.  The voltage of the auxiliary AC power supply can fluctuate ( $\pm 20\%$ ) and ranges from 176 V AC to 300 V AC. L+N or L+N+PE is used. The frequency is 50/60 Hz.  An auxiliary transformer is required for the 420/440/480 V power grid.
External capacity requirements for the auxiliary power supply	Calculate the power distribution capacity based on the number and specifications of the Smart String ESSs (5 kVA)
External requirements for the short-circuit current of the auxiliary power supply	The calculated short-circuit current of the AC input port of the auxiliary power supply should be less than or equal to 10 kA. The current of the auxiliary power supply should not exceed 10 kA. It is recommended that a 40 A 10 kA 2P MCB be used.
Power supply requirements for the monitoring system	One single-phase power switch needs to be reserved to supply 220 V AC power to devices such as SmartLogger and PoE power supply. The power is 110 W.
Layout requirements for the foundation and surrounding areas	The foundation must be properly designed based on the foundation reference diagram and cable connection diagram. The ground around the foundation (see the layout diagram sheet) must be flat to facilitate installation and O&M using a forklift (see

Key Design Point	Description
	the foundation diagram).
Earthing system	TN-S, TN-C, TN-C-S, TT, and IT
Grounding requirements	The ground terminal of the ESS must be grounded through a cable or hot-dip zinc-coated flat steel sheet.
Storage requirements	Storage temperature: $-35^{\circ}\text{C}$ to $+60^{\circ}\text{C}$ (The recommended range is $0^{\circ}\text{C}$ to $30^{\circ}\text{C}$ . If the ESS is stored at a temperature higher than $40^{\circ}\text{C}$ for extended periods, the battery performance and service life may be deteriorated.) Relative humidity: 5%–95% RH
Mapping relationship	Huawei SmartLogger3000 must be used.
Prefabrication before transportation	Prefabrication before transportation is supported.
Fire suppression equipment	It is recommended that the project site be equipped with two to five dry powder fire extinguishers for each ESS, which should be stored next to the ESS.
Auxiliary power supply requirements	It is recommended that the auxiliary power supply be connected to the customer's power distribution cabinet. For the 380 V, 400 V, or 415 V power grid, the auxiliary power can be obtained through the PCS port in the cabinet. The cable is delivered with the cabinet and connected to phase C and phase N of the PCS port. The power meter on the customer side displays phase C power imbalance.
Cable selection	Three-core, four-core, or five-core outdoor copper, copper-clad aluminum, or aluminum alloy cable with a cross-sectional area of 50–300 mm <sup>2</sup>
Charge requirements	Ensure that the ESS is powered on within 7 months after delivery. If the ESS might not be powered on and connected to the power grid within 7 months, notify Huawei in advance.
System configuration	A grid connection point corresponds to one SmartLogger and one power meter.
ESS control mode	<ul style="list-style-type: none"> <li>8. Maximum self-consumption (PV+ESS scenario)</li> <li>9. TOU (PV+ESS or ESS-only scenario in which the electricity prices in peak and off-peak hours are different and a power meter is available)</li> <li>10. TOU (fixed power) (PV+ESS scenario or ESS-only scenario in which the electricity prices in peak and off-peak hours are different and no power meter is available)</li> <li>11. Charge/Discharge based on dispatch (third-party controller scenario)</li> <li>12. <b>Peak shaving (can be overlaid with modes 1 and 2)</b></li> <li>13. <b>Power boost</b></li> </ul>
Fitting bag for fiber ring switching	If the fiber ring network is used, the fitting bag for fiber ring switching must be configured, including pigtailed and optical

Key Design Point	Description
	<p>modules.</p> <p>Gigabit single-mode optical modules must be used at the central site (central control room or management system site). Four-core or eight-core single-mode armored optical cables with a transmission wavelength of 1310 nm and an outer diameter less than 18 mm must be used.</p>
Scenario in which the SmartLogger is integrated into the ESS	<p>Applicable only to the single-ESS scenario in which the ESS is connected to the management system. Otherwise, the SmartLogger cannot be integrated into the ESS to achieve the safety black box function.</p> <p>In this scenario, the SmartLogger, 4G antenna (if 4G networking is required), and SmartLogger cables need to be connected.</p>
ESS networking solution	FE networking is recommended for the ESSs. Optical fiber networking is also supported.
Maximum number of devices that can be connected to the system	A single SmartLogger supports a maximum of 20 C&I ESSs and 30 PV inverters. Each M3 inverter can connect to a maximum of 115 optimizers, and each V6 inverter can connect to a maximum of 240 optimizers.
Restrictions on communications networking	When FE networking is used, the communication distance between two points is less than or equal to 100 m. An FE ring network supports a maximum of 20 ESSs. A fiber ring network supports a maximum of 20 ESSs.
Adding connected devices	Consult the product SE.
Environment adaptability	<p>Region: (Use the smaller value after confirmation by the SE of each component.) Specifications provided by the MO</p> <p>Operating temperature: <math>-30^{\circ}\text{C}</math> to <math>+55^{\circ}\text{C}</math> (derated when the temperature is higher than <math>50^{\circ}\text{C}</math>)</p> <p>Altitude: <math>\leq 4000</math> m</p>
Application scenarios	The ESS is IP55-rated and fit for outdoor deployment.
Maximum number of parallel ESSs	In the ESS-only scenario, a maximum of 50 ESSs can be connected in parallel on the AC side ( <b>50 ESSs can be connected to the low-voltage side of the same transformer.</b> ). In the PV+ESS scenario, a maximum of 20 ESSs and 30 inverters can be connected in parallel.
Restrictions on low-voltage coupling between ESSs and inverters	<p>To prevent the circulating current of the parallel system from exceeding the threshold, the cables from the PCSs and inverters (M3, V5, V5+, and V6) to the parallel connection points on the power distribution cabinet must be at least 5 m long.</p> <p>The solution for the parallel cables for PCSs and V3 inverters is as follows: If the PCS cable is 20 m long, the inverter cable is 15 m long, and the number of V3 inverters is less than or equal to 3, add a high-permeability magnetic ring (code: 17010248) to each phase of each V3 inverter.</p>
Installation requirements	The minimum clearance is 2000 mm in front of the ESS, 400 mm

Key Design Point	Description
	behind the ESS, 750 mm on the left side, and 400 mm on the right side. In the case of 3-sided layout, the minimum clearance is 100 mm from side to side and 300 mm from back to back.
Overall layout requirements	For details about the typical layout, see the user manual.
Zero feed-in requirements	Only the SUN2000-V3/M3/V5/V5+/V6 inverters can be connected to the ESSs in parallel, and <b>2s feed-in prevention is supported</b> .
Solution design	The overall solution must be designed or reviewed by trained product managers or solution design engineers.
Import feasibility assessment	<p>Some countries have special qualification or license requirements for the import of equipment containing dangerous chemicals. In some countries, it is difficult or time-consuming to obtain the permit. Due to changing policies in different countries, if chemicals such as refrigerant and fire suppression agents need to be injected before delivery:</p> <p>If the import is handled by a subsidiary: Confirm with the supply chain of the rep office whether the customs clearance is feasible for the import before signing the contract.</p> <p>If the import is handled by a channel partner: It is recommended that the channel partner be informed of the types and quantities of chemicals in advance to make preparation in advance.</p> <p>In some countries, it is prohibited to fill refrigerant or extinguishant in advance. You need to find other solutions such as local filling.</p>
Others	<p>14. Before sales and shipment, check whether vehicles/mechanical tools can be used for project delivery and whether they can support forklifts with a load-bearing capacity of more than 5 tons.</p> <p>15. The cartons are used only for preventing dust and dirt. If a carton is damaged but the ESS is intact, the customer's goods acceptance shall not be affected.</p>

### NOTICE

This section describes the key points of design and boundary conditions that customers must comply with before using Huawei hybrid air & liquid cooled ESS solution. In the case of any nonconforming items, the system design may be incorrect, the solution may fail to work, or the project operation may be affected.

## 4.3.2 Typical Array Design

The following describes the system configurations and primary wiring diagrams of ESS arrays with different C-rates and power values.

Remarks:

1. The typical design is based on an ambient temperature of 40°C. For areas where the ambient temperature is higher than 40°C, the PCS power will be derated. Therefore, the derating needs to be considered in the design.
2. The typical design is based on the altitude below 4000 m.
3. Full load is supported in the following conditions: altitude of 0 m, temperature within 50°C; altitude of 2000 m, temperature within 40°C; altitude of 4000 m, temperature within 30°C.

**Table 4-1** 1.08 MW/2.15 MWh array BOQ

No.	Item	Specifications	Unit	Quantity	Supplier	Remarks
1	Smart String ESS	LUNA2000-215-2S10, LUNA2000-215-2S12	-	10	Huawei	
2	SACU/SmartLogger	SmartLogger3000	-	1	Huawei	
3	Expansion module	SmartModule	-	1	Huawei	
4	Three-phase meter	SmartPS-80AI-T0	-	1	Huawei	
5	AC power cable for the Smart String ESS	ZC-0.6/1 kV-YJV22-4 x 95 mm <sup>2</sup> + 1 x 50 mm <sup>2</sup>	m	xx	Separately purchased by the customer	-
6	Auxiliary power cable for the Smart String ESS	ZC-0.6/1 kV-YJV22-3 x 6 mm <sup>2</sup>	m	xx	Separately purchased by the customer	-

\*This table is for reference only. For details, see the configuration guide.

### 4.3.3 Typical Layout of a C&I ESS Array

#### 4.3.3.1 Typical Array Layout

The minimum clearance is 2500 mm in front of the ESS, 400 mm behind the ESS, 750 mm on the left side, and 100 mm on the right side. In the case of 3-sided layout, the minimum clearance is 100 mm from side to side and 300 mm from back to back.

Figure 4-4 Typical array layout (0.75 MWh) (single-row layout)

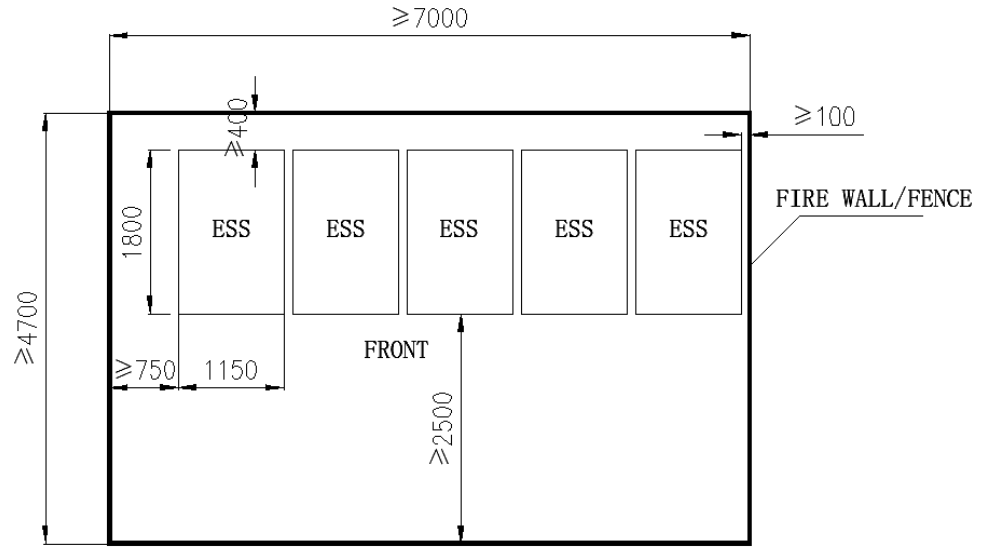
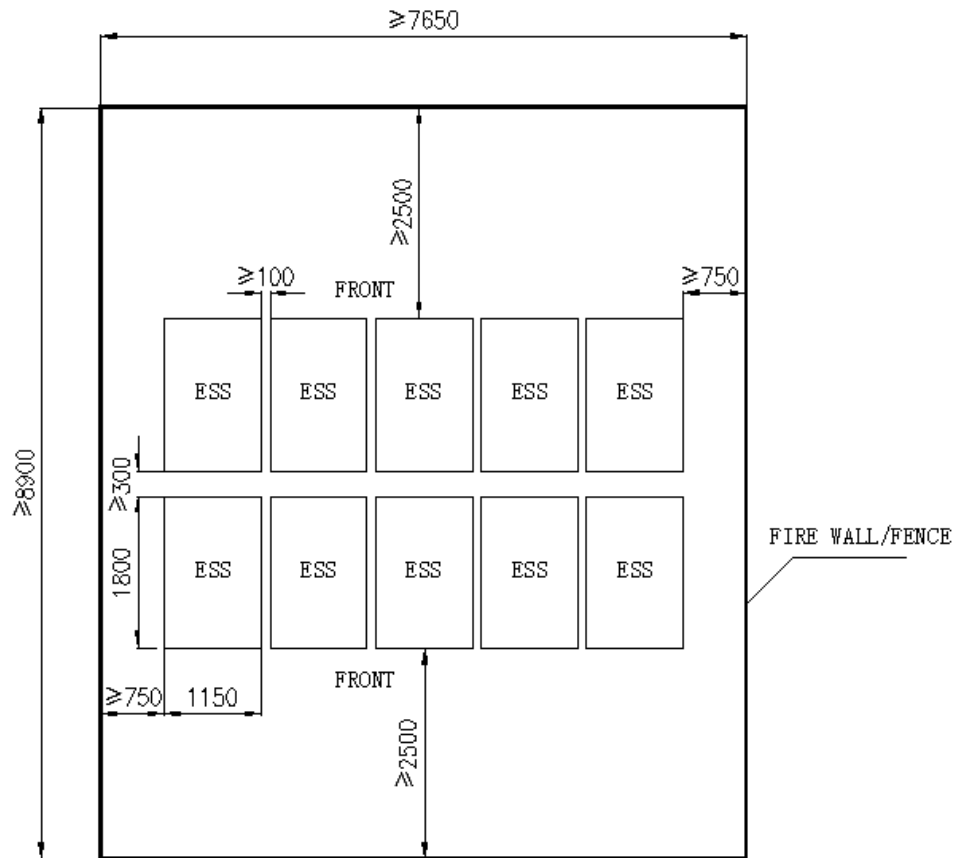

Figure 4-5 Typical array layout (2.15 MWh) (dual-row back-to-back layout)



## 4.3.4 Charge Solution

### Material Delivery Check

There must be a battery charge label on the packing case of the ESS. The charge label must specify the latest charge time and the next charge time.

### Storage Requirements



#### WARNING



- Store the ESS in a dry, clean, and ventilated indoor environment that is free from sources of strong infrared or other radiations, organic solvents, corrosive gases, and conductive metal dust. Do not expose the ESS to direct sunlight or rain. Keep the ESS far away from sources of heat and fire.
- Store the ESS separately to avoid mixing with other equipment. The site must be equipped with qualified fire fighting facilities, such as fire sand and fire extinguishers.

#### CAUTION

It is recommended that the ESS be used soon after being deployed onsite. The ESS that has been stored for an extended period shall be charged periodically. Otherwise, the ESS may be damaged.

- Place the ESS correctly according to the signs on the packing case during storage. Do not place the ESS upside down, lay it on one side, or tilt it.
- The ESS packaging signs are described as follows.

ID	Symbol	Description
Up		The package shall be kept upright during transportation and storage.
Fragile		The package contains fragile objects and shall be handled with care.

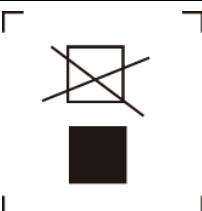
ID	Symbol	Description
Keep dry		The package shall be protected against rain, and rainproof measures shall be taken during transportation and storage.
Do not roll		The package shall not be rolled during transportation.
Do not stack		The package shall not be stacked.

- The storage environment requirements are as follows:
  - Ambient temperature:  $-35^{\circ}\text{C}$  to  $+60^{\circ}\text{C}$  (The recommended range is  $0^{\circ}\text{C}$  to  $30^{\circ}\text{C}$ . If the ESS is stored at a temperature higher than  $40^{\circ}\text{C}$  for extended periods, the battery performance and service life may be deteriorated.)
  - Ambient temperature:  $-30^{\circ}\text{C}$  to  $+55^{\circ}\text{C}$
  - Relative humidity outside the cabinet: 0–100% RH; relative humidity inside the cabinet: 5%–95% RH
  - Dry, clean, and well-ventilated
  - Away from corrosive organic solvents and gases
  - Away from direct sunlight
  - At least 2 m away from heat sources
- The ESS must be disconnected from external equipment during storage, and the ESS indicators must be off.
- The storage duration starts from the latest charge time labeled on the ESS packaging. If the ESS is qualified after charge, update the latest charge time (recommended format: YYYY-MM-DD HH:MM) and the next charge time (Next charge time = Latest charge time + Charge interval) on the label.
- The following table lists the maximum ESS charge intervals. Charge the ESS promptly and calibrate the SOC to at least 50%. Otherwise, the battery performance and service life may be deteriorated.

Storage Temperature (T)	Maximum Charge Interval <sup>a</sup>
$-35^{\circ}\text{C} < T \leq +30^{\circ}\text{C}$	15 months
$30^{\circ}\text{C} < T \leq 40^{\circ}\text{C}$	11 months

Storage Temperature (T)	Maximum Charge Interval <sup>a</sup>
40°C < T < 60°C	7 months
Note a: The interval starts from the latest charge time labeled on the ESS packaging.	

- When stored in low SOC, the ESS must be charged within the maximum interval corresponding to the SOC when the batteries are powered off. If the ESS is not charged within the specified interval, the batteries may be damaged due to overdischarge.

Power-Off SOC Before Storage	Maximum Charge Interval
SOC ≥ 50%	Refer to the charge intervals for batteries delivered separately.
5% ≤ SOC < 50%	20 days
SOC < 5%	48 hours

- Do not remove the packaging from the ESS. If charging is necessary, the ESS must be charged by professionals as required and then returned to their original packaging after charging.
- The warehouse keeper shall collect the ESS storage information every month and periodically report the ESS inventory information. The ESS in long-term storage must be charged promptly.

**⚠ CAUTION**

- Only trained and qualified personnel are allowed to charge batteries. Wear insulated gloves and use dedicated insulated tools during the operation.
  - Observe onsite during charge and handle any exceptions in a timely manner.
  - If a battery experiences an abnormality such as bulging or smoke during charging, stop charging immediately and dispose of it.
- 
- AC mains input voltage requirements for charging:
    - 220 V (three-phase 380–480 V AC and single-phase 176–300 V AC)
    - AC input power cables used for charging the ESS in the warehouse must have a through-current capacity greater than 60 A.
  - If the ESS has been stored for longer than allowed, promptly report the condition to the person in charge.
  - Ensure that the ESSs are delivered on a "first-in, first-out" basis.
  - Handle the ESS with care to prevent damage.

**Maximum ESS Storage Periods**

- Do not store the ESS for extended periods.

- The following table lists the maximum ESS charge intervals. Charge the ESS promptly and calibrate the SOC to at least 50%. Otherwise, the battery performance and service life may be deteriorated.

Storage Temperature (T)	Maximum Charge Interval <sup>a</sup>
-35°C < T ≤ +30°C	15 months
30°C < T ≤ 40°C	11 months
40°C < T < 60°C	7 months
Note a: The interval starts from the latest charge time labeled on the battery package.	

- If the ESS has been stored for longer than allowed, promptly report the condition to the person in charge.
- Dispose of a deformed, damaged, or leaking ESS directly irrespective of how long it has been stored.
- The storage duration starts from the latest charge time labeled on the ESS packaging. If the ESS is qualified after charge, update the latest charge time (recommended format: YYYY-MM-DD HH:MM) and the next charge time (Next charge time = Latest charge time + Charge interval) on the label.
- Batteries can be charged for a maximum of three times during storage. Dispose of batteries if the maximum charge times are exceeded.

## Preparing Charging Devices

- Multimeter
- Clamp meter
- Insulated torque socket wrench

## Checking the ESS Before Charging

- Check the ESS exterior to ensure that the ESS is qualified before charging.
- The ESS is qualified if it is free from the following symptoms:
  - Deformation
  - Enclosure damage
  - Leakage

## Full Charge Strategy

The charging ambient temperature ranges from 15°C to 40°C.

## Charging Procedure

### NOTE

Prepare the ESS that is qualified for charging.

**Step 1** Remove the ESS packaging and open the ESS door.

**Step 2** Connect the PCS port of the ESS to the 380–480 V AC power grid.

- Step 3** Connect the ESS auxiliary power supply to the single-phase 176–264 V power distribution cabinet.
- Step 4** Connect the general BAT+ and BAT– cables of battery packs to the BAT+ and BAT– terminals of the RCM.
- Step 5** (Optional) Turn on the RCM disconnecter.
- Step 6** Turn on the general power circuit breaker of the power distribution cabinet outside the ESS.
- Step 7** Turn on the auxiliary power circuit breaker of the power distribution cabinet outside the ESS.
- Step 8** (Optional) Turn on the auxiliary power circuit breakers QF1 and QF2 of the RCM (applicable when the UPS is used).
- Step 9** Press the WiFi button on the ESS door for more than 3 seconds, and connect to the ESS on the FusionSolar app.
- Step 10** Log in to the FusionSolar app and perform charging operations.
- End

## 4.4 ESS Safety Requirements

### NOTICE

The ESS site selection and fire safety must comply with local laws and regulations. Reference standards include but are not limited to GB 51048 *Design code for electrochemical energy storage station*, GB 50016 *Code for fire protection design of buildings*, and NFPA 855 *Standard for the Installation of Stationary Energy Storage Systems*.

The site of the ESS must meet the site selection requirements in the user manual.

- There must be no combustible materials within 3 m of the ESS or the site to prevent fire from spreading. (Exemption: Single specimens of trees, shrubbery, or cultivated ground cover such as green grass, ivy, succulents, or similar plants used as ground covers shall be permitted to be exempt provided that they do not form a means of readily transmitting fire.)
- You are advised not to add any overhead structure above the ESS. If an overhead structure is necessary in special scenarios, the following conditions must be met: The distance between the overhead structure and the top of the ESS shall be greater than 3 m. The overhead structure shall be non-combustible.

#### China Region:

- The general layout of an energy storage plant with a rated power of 500 kW and a rated energy of 500 kWh or above must comply with section 12.2 in GB 51048 *Design code for electrochemical energy storage station*.
- For an energy storage plant with a rated power of less than 500 kW or rated energy of less than 500 kWh, the distance between the battery equipment and the buildings and roads outside the plant must be greater than or equal to 3 m.

The distance between the battery equipment and the buildings can be reduced to 1 m if any of the following conditions is met:

- A firewall with a fire resistance rating of at least 3 hours is installed between the battery equipment and the buildings. The firewall should be at least 1 m away from the physical boundary of the battery equipment.
- The fire resistance rating of the external walls of the buildings is greater than or equal to 3 hours.
- The ESS located outdoors must be at least 3 m away from parking spaces.

**Outside China:**

- The ESS located outdoors must be at least 10 ft (3.048 m) away from lot lines, public ways, buildings, combustible materials, hazardous materials, high-piled stock, parking spaces, and other exposure hazards not associated with electrical grid infrastructure.
- If either of the following conditions is met, the distance between the ESS and the production building shall be permitted to be reduced to 3 ft (0.914 m). In addition, clearance requirements for equipment transportation, installation, and maintenance shall be considered.
- There are 1-hour freestanding fire walls, extending 5 ft (1.5 m) above and extending 5 ft (1.5 m) beyond the physical boundary of the ESS installation.
- Non-combustible exterior walls with no openings or combustible overhangs are provided on the walls adjacent to the ESS and the fire resistance rating of the exterior walls complies with 2-hour fire resistance rating of ASTM E119 or UL 263.
- The distance between the exhaust device of an ESS and the heating and ventilation vents, air intake vents of air conditioners, windows, doors, unloading platforms, and fire sources of other buildings or facilities must be greater than 4.6 m.

# 5 SmartPVMS (Plant)

---

## 5.1 Introduction

With the rapid development of PV, millions of PV plants have been established around the world. As the scale of PV plants keeps increasing, problems of traditional PV plants, such as high OPEX, inability to share data, and inability to evaluate the plant operational quality, become increasingly prominent. Higher requirements are posed in terms of automatic monitoring and production management, operation evaluation and maintenance, networking, and system reliability of PV plants. Based on the preceding PV plant development trends and customers' requirements, Huawei launched the SmartPVMS.

The SmartPVMS (Plant) provides the monitoring software and value-added features for Huawei PV inverters.

The SmartPVMS (Plant) mainly works with the SUN2000, SUN5000, and LUNA2000 as well as other devices, such as SmartLoggers, Smart Dongles, optimizers, batteries, power meters, and environmental monitoring instruments (EMIs). You can log in to the SmartPVMS (Plant) using a web browser to monitor the performance data and alarms of Huawei grid-tied PV inverters in real time, and remotely control and manage the PV inverters. This achieves centralized management and remote O&M of grid-tied PV inverters.

The system allows you to configure value-added features such as Smart I-V Curve Diagnosis and SDS and displays their results.

The SDS can be configured and started through the SmartLogger. However, the SmartPVMS (Plant) is required to start Smart I-V Curve Diagnosis and display the energy yield comparison. For details about the mapping between features and the SmartPVMS (Plant), see the user manual of the corresponding device.

The SmartPVMS software uses the B/S architecture, consists of the access, common framework, application and service, and UI layers, and runs on the EulerOS. Users can access the server through the WebUI on a device that runs the Windows operating system. The SmartPVMS supports encrypted transmission to ensure data transmission security.

The following figure shows the SmartPVMS software architecture.

Figure 5-1 SmartPVMS software architecture

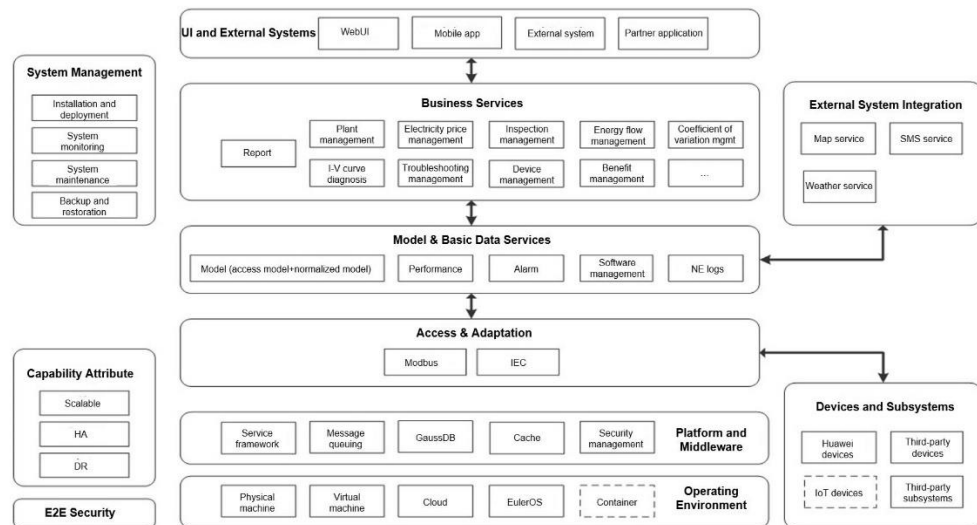

The SmartPVMS monitors Huawei PV devices and their auxiliary devices. The following figures show the system networking diagrams.

Figure 5-2 SmartPVMS components

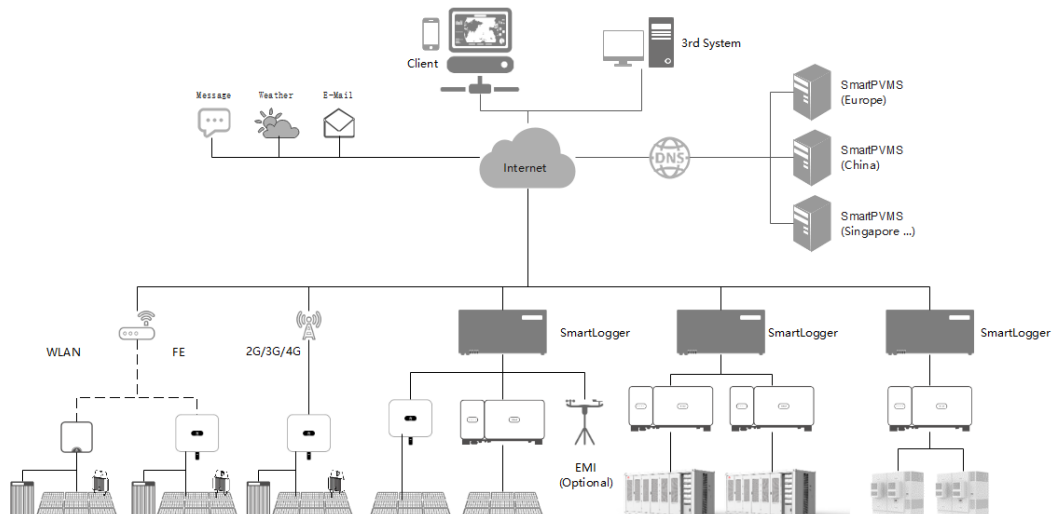

The system consists of the SmartPVMS server, PV devices, third-party services, and clients, which are connected through the Internet.

- The system supports devices such as inverters/PCSs, power meters, optimizers, EMIs, residential ESSs, utility-scale ESSs, and C&I ESSs.
- Inverters can connect to the system through the SmartLogger or Dongle.
- The SmartPVMS uses a firewall as the primary protection.
- Services such as the DNS, email, weather forecast, and map are mainly provided by third-party providers.

- Clients mainly include user PCs and smart phones.

## 5.2 Features

### Simple Management and Monitoring Platform for All Scenarios

- Applies to all scenarios, including the residential, C&I, and utility-scale scenarios.
- The multi-layer user architecture is used, which is applicable to distributed scenarios, facilitating user management.
- Multiple roles are defined for proper permission assignment to user accounts.

### Lifetime Management for a Full Knowledge of the Plant Status

- Plant information on one screen, facilitating management
- Real-time monitoring of plant-level, device-level, and module-level running data
- Traceable and presentable plant-level and device-level historical data of multiple types
- Real-time display of fault alarms, facilitating quick response and troubleshooting
- Report and alarm push and subscription to gain visibility into plant operation

### Intelligent and Efficient O&M

- Simple and efficient centralized O&M and monitoring
- Real-time alarm push and troubleshooting suggestions for quick response
- Accurate locating of arc faults, reducing the onsite troubleshooting time (full optimizer configuration required)
- Intelligent diagnosis and warning, detecting device exceptions in advance
- Mobile O&M/Electronic tickets, delivering simple and efficient O&M
- Remote health check and proactive optimization, ensuring the healthy and stable operation of plants

# 6 Appendix A: Technical Specifications

---

For details, see the *C&I ESS 215 kWh Series Technical Data*.

# 7

## Appendix B: Model Mapping for the PV+ESS Solution

---

For details, see the *C&I ESS 215 kWh Series Device Model Matrix for PV+ESS Solution*.